

NK10T Operation Manual

1 Product Description

- Built-in High-performance, Low-power Microcontroller
- Peripheral Features
 - Support 4-20mA and 0-5V/10V two given
 - Two switch inputs
 - Wide Range Of Primary Loop Voltages (AC110-440V)
- Efficient cooling solution such small size, light weight
- Practical alarm function
 - Phase failure
 - Overheat
 - Overcurrent
 - Load break
- One relay output
 - 3A AC250V
 - 3A DC30V
- Max Current 150A
- To facilitate centralized control RS485 communication

2 Size

2.1 0-40A

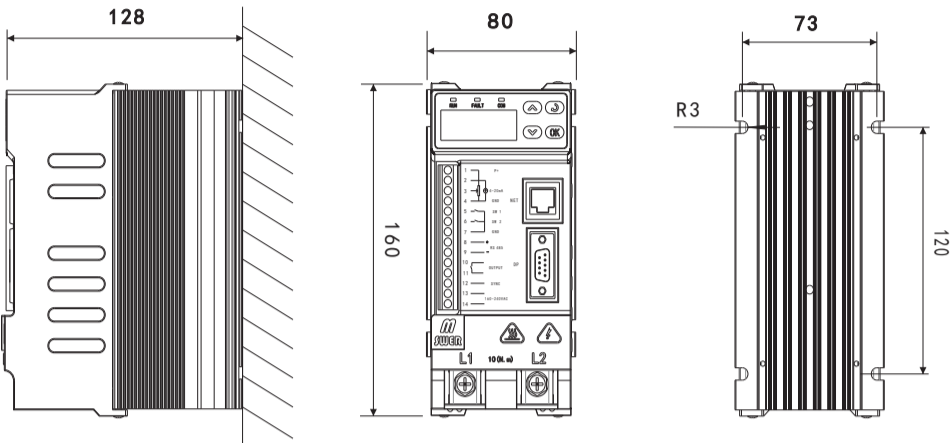

2.2 75-150A

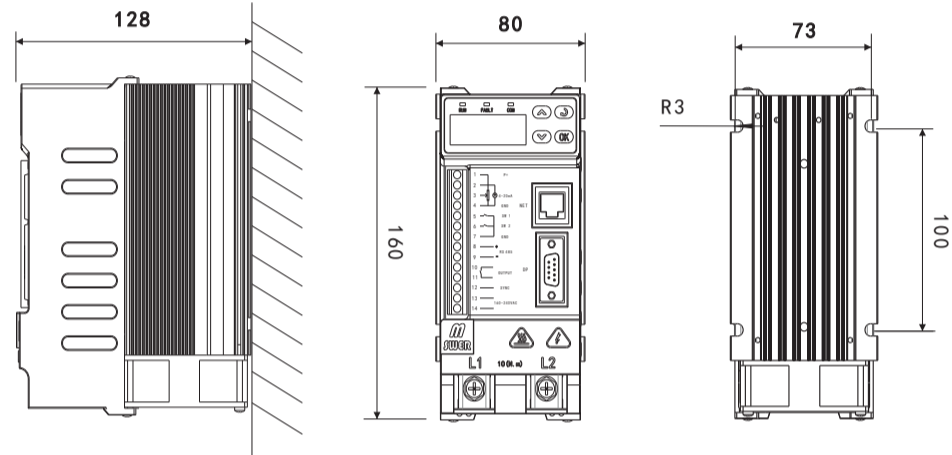

(Unit: mm)

3 Keyboard operation

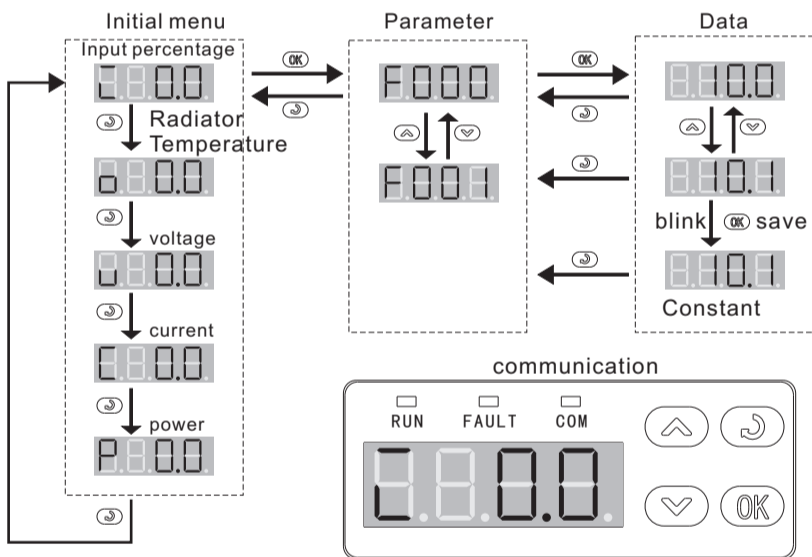

4 Terminal description

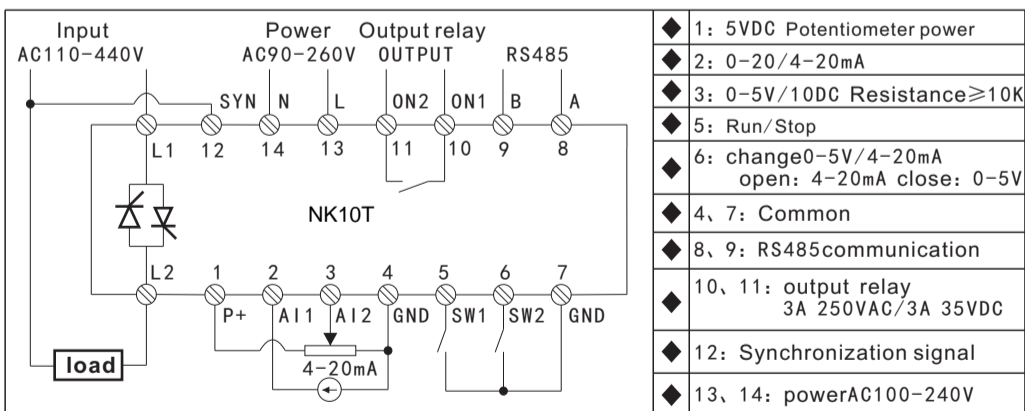

5 Communication

10T Series power regulator supports Modbus-RTU protocol.

- ▶ function: supports 3, 4, 6, 16
- ▶ baud rate: 2400 4800 9600 19200 38400
- ▶ data format: 8n2, 8e, 8o1
- ▶ station address: 1-247
- ▶ register: 16 bit unsigned integer

Notice: every frame cannot exceed 20 bytes, so every frame can maximum read 10 parameters. decimal point is not supported. For example, before writing 56.7, it should be adjusted as 567 and then re-write. The register of the host computer starts from 1 and the register number is incremented by 1. If the register number is F004, it should be filled with 5.

▶ Read Holding Registers frame format

0	1	2	3	4	5	6	7
Addr	Function 03H	Starting Address Hi	Starting Address Lo	No. of Points Hi	No. of Points Lo	CRC H	CRC L

▶ Preset Single Register frame format

0	1	2	3	4	5	6	7
Addr	Function 06H	Starting Address Hi	Starting Address Lo	Preset Data Hi	Preset Data Lo	CRC H	CRC L

6 basic parameter

Above chapter is the brief operation parameter, R: readable parameter, RW: readable and writeable parameter. Please change parameter when regulator stops.

parameter no.	description	range	default	Attributes	Register
F-000	input value	0-100.0 [%] 0.1%	-	F-055=0 R	0
F-004	output voltage	0-3000.0 [V] 0.1V	-	F-055=0 R	4
F-005	output current	0-3000.0 [A] 0.1A	-	F-055=0 R	5
F-006	output power	0-3000.0 [KW] 0.1KW	-	F-055=0 R	6
F-017	Current fault	0-100	-	F-055=35 R	17
F-030	Set-point through communication	0-100.0 [%] 0.1%	0	F-055=35 RW	30
F-055	Menu Authority 0: Read-only parameter is displayed 35: Display simple parameter and read-only parameter	0-3000	0	F-055=0 RW	55
F-061	Reference types 50: Analog value set-point 51: Set-point through communication	33-54	50	F-055=35 RW	61
F-065	Digital given type 0: Keypad set-point 1: communication	0-1	0	F-055=35 RW	65
F-066	Digital setting power saving 0: saving 1: not saving	0-1	0	F-055=35 RW	66
F-069	Ramp time	0-120S	2	F-055=35 RW	67
F-077	Rated voltage: The same as nameplate. Data can be changed according to actual load, for the purpose of protecting device	0-3000 [V] 1V	380	F-055=35 RW	77
F-086	Feedback signal type 7: voltage 8: current 9: power	0-33 1	7	F-055=35 RW	86
F-099	A12 Signal types 0: 0-5V 1: 0-10V	0-1 1	0	F-055=35 RW	99
F-111	Feedback Type 0: Open loop 1: closed loop	0-1 1	1	F-055=35 RW	111
F-114	Trigger Mode 0: Phase shifter 1: Zero trigger	0-1 1	1	F-055=35 RW	114
F-125	Previous fault type	-	-	F-055=0 RW	125
F-127	Power fault protection enables 0: Disable 1: alarm 2: alarm+relay 3: alarm+relay+stop	0-3 1	2	F-055=35 RW	127
F-128	Load fault protection enables 0: Disable 1: alarm 2: alarm+relay 3: alarm+relay+stop	0-3 1	0	F-055=35 RW	128
F-129	Load-off threshold	10-70 [%] 1%	70	F-055=35 RW	129
F-133	device address Setting address of Modbus and Profibus	1-247 1	123	F-055=35 RW	-
F-134	baud rate 0: 2400 1: 4800 2: 9600 3: 19200 4: 38400	0-4 1	2	F-055=35 RW	-
F-135	Data format 0: 8n2 Date bit 8 bits, no calibration, 2 stop bits 1: 8e1 Date bit 8 bits, parity - checking, 1 stop bits 2: 8o1 Date bit 8 bits, odd parity -checking, 1 stop bits 3: 8n1 Date bit 8 bits, no calibration, 1 stop bits	0-3 1	1	F-055=35 RW	-
F-140	Hardware edition	-	-	F-055=0 R	-
F-141	Software edition	-	-	F-055=0 R	-

7 Fault and maintenance

7.1 Fault list

fault code	description
E002	Main power fault, possible fault reason: 1. No voltage of mail loop or not the same of nameplate. 2. Synchronous cable of terminal 12 is not connected, please refer to the wiring drawing.
E003	Overcurrent, measured current exceeds 1.25 time of rated current, possible reason: 1. Load changes rapidly or short-circuit. 2. Thyristor breaks.
E004	Load-off, current <set-point percentage * rated current * load threshold, Possible reason: 1. Load off 2. Load current is small 3. Setting of (F-129) is large
E005	Overheat of regulator, heat-sink temperature is bigger than 85, possible reason: 1. Ambient temperature is higher than 45. 2. Fan breaks. 3. Dust on the ventilation path.
E009	Overload of regulator, load current is bigger than rated current of regulator.
E010	Thyristor breaks, Thyristor damage detected alarm is activated.

7.2 daily maintenance

Fault might happen because of using temperature, humidity, dust and some other reason, daily maintenance is needed, user can do the check and maintain within 3~6 months, checking lists are as below:

- 1: Main loop connector.
- 2: Clean PCB board, ventilation, fans.
- 3: Regulator should be electricity every 3 months if not use.
- 4: Prevent from high temp. humidity and metal powder location.
- 9.3 spare part/maintain

- 1: Please contact service centre + 86 029-83754508 for maintenance.
- 2: Please contact NOKER for buying spare parts.

8 Order no. code

NK10T — [] [] [] — []
Single-phase power regulator Rated current (A) : Optional

Optional: P Profibus DP
C MODBUS TCP/IP
T Temperature function
R TRMS vaue